

# ICC-ES Evaluation Report

**ESR-1147**

Reissued December 2023

This report also contains:

Revised June 2024

- CBC Supplement

Subject to renewal December 2024

ICC-ES Evaluation Reports are not to be construed as representing aesthetics or any other attributes not specifically addressed, nor are they to be construed as an endorsement of the subject of the report or a recommendation for its use. There is no warranty by ICC Evaluation Service, LLC, express or implied, as to any finding or other matter in this report, or as to any product covered by the report.

Copyright © 2024 ICC Evaluation Service, LLC. All rights reserved.

<p><b>DIVISION: 03 00 00— CONCRETE</b></p> <p><b>Section: 03 11 19— Insulating Concrete Forming</b></p>	<p><b>REPORT HOLDER:</b></p> <p><b>INTEGRASPEC CORPORATION</b></p>	<p><b>EVALUATION SUBJECT:</b></p> <p><b>INTEGRASPEC INSULATING CONCRETE FORMS (ICF)</b></p>	
---	--	---	---

## 1.0 EVALUATION SCOPE

### 1.1 Compliance with the following codes:

- 2018, 2015, 2012 and 2009 [International Building Code® \(IBC\)](#)
- 2018, 2015, 2012 and 2009 [International Residential Code® \(IRC\)](#)
- 2006 [International Building Code® \(2006 IBC\)](#)\*
- 2006 [International Residential Code® \(2006 IRC\)](#)\*

\*Codes indicated with an asterisk are addressed in Section 8.0

- 2013 *Abu Dhabi International Building Code (ADIBC)*†

†The ADIBC is based on the 2009 IBC. 2009 IBC code sections referenced in this report are the same sections in the ADIBC.

For evaluation for compliance with codes adopted by the California Office of Statewide Health Planning and Development (OSHPD) AKA: California Department of Health Care Access and Information (HCAI) and the Division of the State Architect (DSA), see [ESR-1147 CBC and CRC Supplement](#).

### Properties evaluated:

- Structural
- Surface burning characteristics
- Attic and crawl space fire installation
- Types I through IV (noncombustible) construction

### 1.2 Evaluation to the following green code:

- 2022 [California Green Building Standards Code \(CALGreen\)](#), Title 24, Part 11

### Attributes verified:

- See Section 3.1

## 2.0 USES

Integraspec insulating concrete forms (ICFs) are used as stay-in-place forms for structural concrete, load-bearing and nonload-bearing exterior and interior walls; beams and lintels; and foundation and retaining walls. The forms remain in place after placement of concrete and must be protected by an approved interior and exterior finish material as described in Sections 4.2.2 and 4.2.3 of this report, respectively. The forms may be used in Type V construction and in construction permitted under the IRC; for use in buildings of Types I, II, III and IV (noncombustible) construction, installation must be in accordance with Section 4.3.

## 3.0 DESCRIPTION

### 3.1 General:

The Integraspec ICFs are classified as a flat ICF wall system in accordance with ASTM E2634 as specified in the 2018 and 2015 IBC Section 1903.4, 2012 IBC Section 1903.3, 2018 and 2015 IRC Section R404.1.3.3.6.1(5), and R608.4.4, 2012 IRC Section R404.1.2.3.6.1(5) and R611.4.4 and 2009 IRC Section 611.3.1, as applicable.

The attributes of the ICFs have been verified as conforming to the requirements of (i) CALGreen Section A4.404.3.3 for prefabricated building systems. Note that decisions on compliance for those areas rest with the user of this report. The user is advised of the project-specific provisions that may be contingent upon meeting specific conditions, and the verification of those conditions is outside the scope of this report. These codes or standards often provide supplemental information as guidance.

### 3.2 Materials:

**3.2.1 Integraspec Insulating Concrete Forms:** Integraspec ICFs consist of two dovetailed expanded polystyrene (EPS) foam plastic face panels connected with plastic web spacers perpendicular to the EPS panels, forming a hollow-core ICF form. The spacers slide into plastic channel inserts molded into the interior face of the EPS panels. See [Figure 1](#) of this report.

The forms are available in a standard length of 48 inches (1219 mm), an interlocked height of 12<sup>1</sup>/<sub>4</sub> inches (311mm) and six standard overall widths, of 9 inches (229 mm), 10 inches (254 mm), 11 inches (279 mm), 13 inches (330 mm), 15 inches (381mm), and 17 inches (432 mm). The six widths have concrete core widths of, respectively, 4 inches (102 mm), 5 inches (127 mm), 6 inches (152 mm), 8 inches (203 mm), 10 inches (254 mm), and 12 inches (305 mm). The forms have interlocking edges at the top, bottom and sides. The 9-, 10-, 11-, 13-, 15- and 17-inch-wide (229, 254, 279, 330, 381 and 432 mm) forms are filled at the jobsite with concrete to provide a solid monolithic concrete wall.

**3.2.2 Foam Plastic:** The EPS panels are expanded polystyrene foam plastic having a nominal density of 1.5 pcf, and comply with ASTM C578 as Type II. The panels are nominally 2.5 inches thick, and have a flame-spread index of 25 or less and a smoke-development index of 450 or less when tested in accordance with ASTM E84.

**3.2.3 Cross-ties:** The cross-ties consist of channel inserts, which are embedded in the EPS panels; and web spacers, which are used to connect the channel inserts of two panels to assemble the ICF. The high-impact polystyrene channel inserts are molded into each panel at 8 inches (203 mm) on center, and have 1<sup>5</sup>/<sub>8</sub>-inch-wide (41 mm) flanges that are recessed <sup>3</sup>/<sub>4</sub>-inch (19.1 mm) from the outer EPS panel surface; and a C-channel that is flush with the inner surface of the EPS panel to enable slotting of web spacers. The high-impact polystyrene web spacers are available in sizes to assemble ICFs to form 4-, 5-, 6-, 8-, 10- and 12-inch-thick (102, 127, 152, 203, 254 and 305 mm) concrete walls. See [Figure 2](#).

**3.2.4 Concrete:** The concrete must be normal-weight concrete, complying with the applicable code, with a maximum <sup>1</sup>/<sub>2</sub>-inch (12.7 mm) aggregate size for 4-, 5- and 6-inch-thick (101, 127 and 152 mm) concrete walls and a maximum <sup>3</sup>/<sub>4</sub> inch (19 mm) aggregate size for 8-inch-, 10-inch-, and 12-inch-thick (203, 254 and 305 mm) concrete walls. Concrete must have a minimum compressive strength of 2,500 psi (17.24 MPa) [minimum of 24 MPa is required under ADIBC Appendix L, Section 5.1.1] at 28 days. Under the IRC, the concrete must comply with IRC Sections R404.1, R608.5.1 (2018 and 2015 IRC) and R611.5.1 (2012 and 2009 IRC)

**3.2.5 Reinforcement:** Walls must be reinforced with deformed steel reinforcing bars having a minimum specified yield strength of 40,000 psi (275 MPa) or 60,000 psi (414 MPa). Under the IBC, the deformed steel bars must comply with Section 20.2.1.3 of ACI 318-14 (2018 and 2015 IBC), Section 3.5.3.1 of ACI 318-11 or -08 (2012 and 2009 IBC) and IBC Section 1903; under the IRC, reinforcement must comply with IRC Sections R404.1.3.3.7 and R608.5.2 (2018 and 2015 IRC) and R404.1.2.3.7 and R611.5.2. (2012 and 2009 IRC).

**3.2.6 Other Components:** When required by the code official, wood members in contact with concrete for plates or window and door framing, must be pressure-treated in accordance with the applicable code or be of a naturally-durable species, and must be attached with hot-dipped galvanized steel fasteners in accordance with IBC Section 2304.10.5 (2018 and 2015 IBC), 2304.9.5 (2012 and 2009 IBC) or IRC Section R317.3, as applicable. Materials other than wood are permitted for window and door framing if approved by the code official.

**3.2.7 Standard and Accessory Forms:** Standard and accessory forms include the Standard Form Unit; 90° Corner Unit; 45° Corner Unit; Taper Top Panel; Integra-Buck; and IntegraT-wall.

## 4.0 DESIGN AND INSTALLATION

### 4.1 Design:

**4.1.1 IBC Design Method, Including Alternate IBC Wind Design in Accordance with ICC-600:** Concrete walls formed by Integraspec ICFs must be designed and constructed in accordance with IBC Chapters 16 and 19, as applicable. Footings and foundations must be designed and constructed in accordance with IBC Chapter 18.

Solid concrete walls formed by flat ICFs may be designed and constructed in accordance with the prescriptive provisions of Section 409 of the ICC Standard for Residential Construction in High Wind Regions (ICC 600-14) under the 2018 and 2015 IBC, or Section 209 of the ICC Standard for Residential Construction in High Wind Regions (ICC 600-2008) under the 2012 and 2009 IBC, as applicable, subject to the limitations in IBC Section 1609.1.1 Exception 1 and IBC Section 1609.1.1.1. Design and construction under the provisions of ICC 600-14 or -08 are limited to the resistance of wind forces.

**4.1.2 IRC Design Method:** Insulating concrete walls formed by the Integraspec ICFs, which comply with Section R608.3.1 (2018 and 2015 IRC) or R611.3.1 (2012 and 2009 IRC) as flat insulating concrete wall forms, must be designed and constructed in accordance with Sections R404.1.3 (2018 and 2015 IRC), R404.1.2 (2012 and 2009 IRC), R608 (2018 and 2015 IRC) and R611 (2012 and 2009 IRC), for flat wall systems. Integraspec ICFs not complying with the dimensional requirements found in Table R608.3 (2018 and 2015 IRC) or R611.3 (2012 and 2009 IRC) [i.e., solid concrete walls thicker than 10 inches (254 mm)] must be designed and constructed in accordance with the provisions of Section 4.1.1 of this report.

The 4- and 5-inch-thick (102 and 127 mm) concrete walls are limited to above-grade construction in accordance with Section R608 (2018 and 2015 IRC) or R611 (2012 and 2009 IRC).

Footings and foundations must be designed and constructed in accordance with IRC Chapter 4.

**4.1.3 Alternate IRC Design Method:** When the Integraspec ICFs are used to construct buildings that do not conform to the applicability limits of Sections R404.1.3 (2018 and 2015 IRC), R404.1.2 (2012 and 2009 IRC), R608.2 (2018 and 2015 IRC) and R611.2 (2012 and 2009 IRC), construction must be in accordance with the prescriptive provisions of the 2012 (for the 2018 and 2015 IRC), 2010 (for the 2012 IRC) or the 2007 (for the 2009 IRC) Prescriptive Design of Exterior Concrete Walls (PCA 100), or the structural analysis and design of the concrete must be in accordance with ACI 318, and IBC Chapters 16, 18 and 19 as noted in Section 4.1.1 of this report.

### 4.2 Installation:

**4.2.1 General:** The Integraspec ICFs must be installed in accordance with this report, the applicable code and Integraspec Corporation's published installation instructions. The published installation instructions and this report must be strictly adhered to, and a copy of these instructions must be available at the jobsite at all times during installation.

The Integraspec ICF wall system must be supported on concrete footings complying with IBC Chapters 18 and 19, or IRC Chapter 4, as applicable. Vertical reinforcement bars embedded in the footing must extend into the base of the wall system the minimum development length necessary for compliance with Chapter 11 and 25 (ACI 318-14) or Chapter 12 (ACI 318-11 or ACI 318-08) (IBC and IRC). Vertical and horizontal reinforcement bars must have concrete protection in accordance with, and must be placed as required by, the design and the applicable code. Additional reinforcement around doors and windows must be described in the approved plans. Concrete quality, mixing and placement must comply with IBC Chapter 19 or Sections R404.1.3.3 (2018 and 2015 IRC), R404.1.2.3 (2012 and 2009 IRC), R608.5.1 (2018 and 2015 IRC) and R611.5.1 (2012 and 2009 IRC), as applicable. Window and door openings must be built into the forms, with the same dimensions as the "rough stud opening" specified by the window or door manufacturer, prior to the placement of the concrete. Connections of concrete walls to footings, floors, ceilings and roofs must be in accordance with Section R608.9 (2018 and 2015 IRC), R611.9 (2012 and 2009 IRC), or be engineered in accordance with the IBC, whichever code is applicable. Anchor bolts used to connect wood ledgers and plates to the concrete must be cast in place, with the bolts sized and spaced as required by design and the applicable code. Details must be prepared to accommodate the specific job situation, in accordance with the applicable code and the requirements of this report, subject to the approval of the code official.

#### 4.2.2 Interior Finish:

**4.2.2.1 General:** The installation details in this section (Section 4.2.2) address compliance with the thermal barrier and interior finish requirements of the codes. The interior side of the forms must be covered with a thermal barrier consisting of minimum  $\frac{1}{2}$ -inch-**thick** (12.7 mm) gypsum wallboard complying with ASTM C36 or ASTM C1396. The gypsum wallboard must be placed either vertically or horizontally and must be attached to the flanges of the cross-ties with minimum  $1\frac{5}{8}$ -inch-long (41 mm), No. 6, Type W, coarse-thread gypsum wallboard screws spaced 12 inches (305 mm) on center horizontally and 16 inches (406 mm) on center vertically. The screws must be of sufficient length to penetrate beyond the back side of the cross-tie flanges a minimum of  $\frac{1}{4}$  inch (6.4 mm). Gypsum wallboard joints must be taped and filled with joint compound in accordance with GA-216 or ASTM C840. See Section 4.2.2.2 for installation details when used as walls of attics or crawl spaces without a covering on the interior face.

**4.2.2.2 Attic and Crawl Space Installation:** When the Integraspec ICFs are used as walls of attics and crawl spaces and no ignition barrier is applied to the interior space side of the foam plastic, all of the following conditions must be met:

- Entry to the attic or crawl space is only to service utilities, and no storage is permitted.
- There are no interconnected attic or basement areas.
- Air in the attic or crawl space is not circulated to other parts of the building.
- Attic ventilation is provided when required by Section 1202.2.1 (2018 and 2015 IBC), 1203.2 (2012 and 2009 IBC) or IRC Section R806, as applicable.
- Under-floor (crawl space) ventilation is provided when required by Section 1202.4 (2018 and 2015 IBC), 1203.3 (2012 and 2009 IBC) or IRC Section R408.1, as applicable.
- Combustion air is provided in accordance with IMC (*International Mechanical Code*<sup>®</sup>) Section 701.

#### 4.2.3 Exterior Finish:

**4.2.3.1 Above Grade:** The Integraspec ICFs must be covered on the exterior with an approved wall covering in accordance with the applicable code or a current ICC-ES evaluation report. Under the IRC, the walls must be flashed in accordance with Section R703.4 (2018 and 2015 IRC) or R703.8 (2012 and 2009 IRC). The approved exterior wall covering must be attached to the flanges of the cross-ties with No. 8, Type W, coarse-thread gypsum wallboard screws. The screws must be corrosion-resistant and have sufficient length to penetrate beyond the back side of the cross-tie flange a minimum of  $\frac{3}{8}$  inch (9.5 mm). The screws have an allowable withdrawal capacity of 28 pounds (125 N) and a lateral capacity of 57 pounds (254 N). The fastener spacing must be designed to support the gravity loads of the wall covering and resist the negative wind pressures. The negative wind pressure capacity of the exterior finish material must be the same as that recognized in the applicable code for generic materials, or that recognized in a current ICC-ES evaluation report for proprietary materials.

**4.2.3.2 Below Grade:** Materials used to dampproof below-grade walls must be specified by Integraspec Corporation and must be free of solvents, hydrocarbons, ketones and esters that will adversely affect the EPS foam plastic. Applicable dampproofing and waterproofing requirements are in IBC Section 1805 and IRC Section R406, as applicable. Compliance is required with the drainage requirements in IBC Section 1804 or IRC Section R405.1, as applicable. No backfill may be applied against the wall until the complete floor system is in place, unless the wall is designed as a freestanding wall that does not rely on the floor system for structural support.

**4.2.4 Foundation Walls:** Integraspec ICFs used as a foundation stem wall when supporting wood-framed or concrete construction must be supported on concrete footings complying with the applicable code. Design and installation of the Integraspec ICFs as foundation stem walls must comply with IBC Section 1807.1.5 or Sections R404, R404.1.3 (2018 and 2015 IRC), R404.1.2 (2012 and 2009 IRC), as applicable. For concrete foundation walls under the IRC, vertical reinforcement size and spacing must be in accordance with IRC Tables R404.1.2(2), R404.1.2(3), R404.1.2(4) and R404.1.2(8). For concrete foundation walls under the IBC, vertical reinforcement size and spacing must be in accordance with IBC Table 1807.1.6.2. Under the IRC, alternate design and construction may be in accordance with ACI 318, ACI 332 or PCA 100.

**4.2.5 Retaining Walls:** Integraspec ICFs used to form concrete retaining walls must be reinforced with steel reinforcing bars designed in accordance with accepted engineering principles and Section 4.1.



**4.2.6 Protection Against Termites:** Where the probability of termite infestation is defined as “very heavy” by the code official, the foam plastic must be installed in accordance with 2012 IBC Section 2603.9, 2018, 2015 and 2009 IBC Section 2603.8 or IRC Section R318.4, as applicable. Areas of very heavy termite infestation must be determined in accordance with 2012 IBC Figure 2603.9, 2018, 2015 and 2009 IBC Figure 2603.8 or IRC Figure R301.2(6), as applicable.

### 4.3 Types I, II, III and IV (Noncombustible) Construction:

**4.3.1 General:** The assemblies described in this section (Section 4.3) comply with IBC Section 2603.5.

**4.3.2 Interior Finish:** The interior side of the forms must be covered with a thermal barrier consisting of minimum 1/2-inch-thick (12.7 mm) regular gypsum wallboard installed as described in Section 4.2.2.1. Other interior finish thermal barriers are acceptable, provided they are equivalent to minimum 1/2-inch-thick (12.7 mm) regular gypsum wallboard, and applied in accordance with a current ICC-ES evaluation report.

**4.3.3 Exterior Finish:** One of the following exterior finishes, described in Sections 4.3.3.1 through 4.3.3.3, must be installed over the exterior of the ICFs:

**4.3.3.1 EIFS and One-coat Stucco:** The below-listed EIFS (exterior insulation and finish system) or one-coat stucco lamina may be installed over the exterior of the forms using the reinforcing fabric or lath, base coat and finish coat materials described in the applicable ICC-ES evaluation report. Installation of the lamina must be in accordance with the wall covering manufacturer’s published installation instructions, specific to ICFs.

- Parex USA, Inc., WaterMaster DB System as described in [ESR-2562](#).

- Sto Corp. StoTherm Classic NEXt as described in [ESR-1748](#).

- Omega Products International, Inc., Omega Diamond Wall One Coat Stucco as described in [ESR-1194](#).

**4.3.3.2 Exterior Cement Plaster:** Metal lath and exterior cement plaster must comply with the IBC, and the exterior plaster must be a minimum of 7/8 inch (22 mm) thick. The lath must be attached to the flanges of the cross-ties with fasteners as described in Section 4.2.3.1.

**4.3.3.3 Brick Veneer:** Anchored brick veneer must be attached to the flanges of the cross-ties with fasteners as described in Section 4.2.3.1. The brick veneer must comply with the IBC and must be installed with a minimum 1-inch (25.4 mm) air gap between the exterior face of the EPS and the brick. The brick must be supported on a steel shelf angle attached to concrete at each floor line and at the top of each window and door opening, in accordance with the IBC.

**4.3.4 Fire-blocking:** Foam plastic on the interior sides of walls must be discontinuous at floor lines. Floor-to-wall intersections must be constructed to prevent the passage of flame, smoke and hot gases from one story to another. Details of floor-to-wall intersections must be provided to the code official. See [Figure 3](#) for typical details.

### 4.4 Special Inspections:

**4.4.1 IBC:** Special inspection is required as noted in IBC Section 1704 for placement of reinforcing steel and concrete, and for concrete cylinder testing. Special inspections, in accordance with IBC Sections 1704.2 (2018, 2015 and 2012 IBC), 1704.1 (2009 IBC), 1705.16 (2018 and 2015 IBC), 1705.15 (2012 IBC) and 1704.14 (2009 IBC), as applicable, are required when an EIFS wall covering is applied. Duties of the special inspector include verifying field preparation of materials, expiration dates, installation of components, curing of components, and installation of joints and sealants.

**4.4.2 IRC:** For walls designed and constructed in accordance with Section 4.1.2 or PCA 100 as described in Section 4.1.3, special inspection is not required. For walls designed for use under the IRC, in accordance with the IBC as described in Sections 4.1.1 and 4.1.3, special inspection in accordance with Section 4.4.1 is required.

## 5.0 CONDITIONS OF USE:

The Integraspec ICFs described in this report comply with, or are suitable alternatives to what is specified in, those codes listed in Section 1.0 of this report, subject to the following conditions:

**5.1** The ICFs must be manufactured, identified and installed in accordance with this report and Integraspec Corporation’s published installation instructions and the applicable code. If there is a conflict between the published installation instructions and this report, this report governs.

- 5.2 Plastic cross-ties must be stored indoors away from direct sunlight.
- 5.3 Integraspec ICFs must be separated from the building interior as described in Sections 4.2.2.1, except for attic and crawl space construction as described in Section 4.2.2.2 of this report.
- 5.4 When used in attics and crawl space construction as described in Section 4.2.2.2, the Integraspec ICFs must have at least one label as described in Section 7.0 visible in every 160 square feet (14.7 m<sup>2</sup>) of exposed interior wall area.
- 5.5 Use of the Integraspec ICFs is limited to Type V construction as defined in IBC Chapter 6, and to nonfire-resistance-rated construction in accordance with the IRC, except as described in Section 4.3.
- 5.6 When use is in buildings required to be of Types I through IV (noncombustible) construction, as described in Section 4.3, the Integraspec ICFs must have at least one label as described in Section 7.0 visible in every 160 square feet (14.7 m<sup>2</sup>) of wall area, prior to the application of wall covering.
- 5.7 When required by the code official, calculations showing compliance with the design requirements of Section 4.1.1 of this report must be submitted to the code official for approval, except that calculations are not required when the building design is based on the prescriptive methods noted in Sections 4.1.2 and 4.1.3. The calculations and details must be prepared by a registered design professional where required by the statutes of the jurisdiction in which the project is to be constructed.
- 5.8 In areas where the probability of termite infestation is defined as “very heavy” and when ICFs are used with wood construction, the foam plastic must be installed in accordance with Section 4.2.6.
- 5.9 Concrete quality, mixing and placement must comply with IBC Chapter 19 or Section R608.5.1 (2018 and 2015 IRC) or R611.5.1 (2012 and 2009 IRC), as applicable.
- 5.10 Special inspection must be provided in accordance with Section 4.4.
- 5.11 When required by the code official, calculations showing compliance with Sections R608.5.3 (2018 and 2015 IRC), R404.1.3.3.6 (2018 and 2015 IRC), R611.5.3 (2012 and 2009 IRC) and R404.1.2.3.6 (2012 and 2009 IRC) must be submitted to the code official for approval. The calculations and details, establishing that the ICFs provide sufficient strength to contain concrete during placement and that the cross-ties are capable of resisting the forces created by fluid pressure of fresh concrete, must be prepared by a registered design professional where required by the statutes of the jurisdiction in which the project is to be constructed.
- 5.12 The Integraspec ICFs are produced for Integraspec Corporation by APTCO LLC in McFarland, California, under a quality control program with inspections by ICC-ES.

## 6.0 EVIDENCE SUBMITTED

- 6.1 For the 2018, 2015 and 2012 IBC and IRC: Data in accordance with the [ICC-ES Acceptance Criteria for Stay-in-place, Foam Plastic Insulating Concrete Form \(ICF\) Systems for Solid Concrete Walls \(AC353\)](#), dated October 2012 (Editorially revised December 2018).
- 6.2 For the 2009 IBC and IRC: Data in accordance with the [ICC-ES Acceptance Criteria for Stay-in-place, Foam Plastic Insulating Concrete Form \(ICF\) Systems for Solid Concrete Walls \(AC353\)](#), dated October 2010.

## 7.0 IDENTIFICATION.

- 7.1 Each bundle of Integraspec ICF panels bears a label that includes the name and address of Integraspec Corporation; the Integraspec trademark; the manufacturer’s name (APTCO LLC); the evaluation report number (ESR-1147); and the phrase, “Acceptable for use in attics and crawl spaces.” Also, one ICF panel in each bundle is labeled on the outer side of the panel with the same information.

Additionally, web spacers are marked with the size, the manufacturing date and lot number, the word, “Integraspec”, and the evaluation report number (ESR-1147).

- 7.2 The report holder’s contact information is the following:

**INTEGRASPEC CORPORATION**  
774 Baker Crescent, Unit A  
KINGSTON, ONTARIO K7M 6P6  
CANADA  
(613) 634-1319  
[www.integraspec.com](http://www.integraspec.com)  
[info@integraspec.com](mailto:info@integraspec.com)

## 8.0 OTHER CODES

### 8.1 Evaluation Scope:

In addition to the codes described in Section 1.0, the products described in this report were evaluated for compliance with the requirements of the following codes:

- 2006 *International Building Code*® (2006 IBC)
- 2006 *International Residential Code*® (2006 IRC)

The products described in this report comply with, or are suitable alternatives to what is specified in, the codes listed above, subject to the provisions of Sections 8.2 through 8.5.

### 8.1 Uses:

See Section 2.0.

### 8.2 Description:

Same as Section 3.0, except for the following revisions:

- Revise Section 3.2.3 to say that concrete must comply with 2006 IRC Sections R404.4 and R611.6.1.
- Revise Section 3.2.4 to say that steel reinforcement must comply with 2006 IRC Sections R404.4.6 and R611.6.2.
- Revise Section 3.2.5 to say that attachment of wood members in contact with concrete must comply with 2006 IRC Section R319.3.

### 8.3 Design and Installation:

#### 8.4.1 Design:

**8.4.1.1 Method:** Concrete walls formed by the Integraspec ICFs must be designed and constructed in accordance with 2006 IBC Chapters 16 and 19, as applicable. Footings and foundations must be designed and constructed in accordance with 2006 IBC Chapter 18.

**8.4.1.2 IRC Method:** Concrete walls formed by the Integraspec ICFs must be designed and constructed in accordance with 2006 IRC Sections R404.4 and R611 for flat ICF wall systems. Footings and foundations must be designed and constructed in accordance with 2006 IRC Chapter 4.

**8.4.1.3 Alternate IRC Method:** When buildings constructed under the 2006 IRC provisions do not conform to the applicability limits of 2006 IRC Sections R404.4.1 and R611.2, the structural analysis and design of the concrete must be in accordance with ACI 318 and 2006 IBC Chapter 19. The empirical design approach specified in ACI 318 Section 14.5 is applicable to the design of concrete walls formed by the Integraspec flat wall forms.

**8.4.2 Installation:** Same as Section 4.2, except for the following revisions:

- Revise Section 4.2.1 to say that concrete quality, mixing and placement must comply with 2006 IBC Section 1905 or 2006 IRC Section R611.6.1. Anchorage of wood ledger boards supporting bearing ends of joists or trusses to flat ICF walls must be in accordance with 2006 IRC Section R611.8.2, or be engineered in accordance with the IBC, whichever code is applicable.
- Revise Section 4.2.2.2 to say that combustion air is provided in accordance with 2006 IMC Sections 701 and 703.
- Revise Section 4.2.3.2 to say that compliance is required with drainage requirements in 2006 IBC Section 1807.4 or 2006 IRC Section R405.1, as applicable.
- Revise Section 4.2.4 to say that design and installation of foundation stem walls must comply with 2006 IBC Section 1805.5 or 2006 IRC Sections R404 and R404.1.2, as applicable.
- Revise Section 4.2.6 to say that where the probability of termite infestation is defined as “very heavy” by the code official, the foam plastic must be installed in accordance with 2006 IBC Section 2603.8 or 2006 IRC Section R320.5, as applicable.

#### 8.4.3 Types I, II, III and IV (Noncombustible) Construction:

See Section 4.3.

#### 8.4.4 Special Inspection:

**8.4.4.1 IBC:** Special inspection is required as noted in 2006 IBC Section 1704 for placement of reinforcing steel and concrete, and for concrete cylinder testing. Special inspection, in accordance with 2006 IBC Sections 1704.1 and 1704.12, is required when an EIFS wall covering is applied. Duties of the special inspector include verifying field preparation of materials, expiration dates, installation of components, curing of components, and installation of joints and sealants.

**8.4.4.2 IRC:** For walls designed and constructed in accordance with Section 8.4.1.2, special inspection is not required. For walls designed for use under the 2006 IRC, in accordance with Section 8.4.1.3 of this report, special inspection in accordance with Section 8.4.4.1 is required.

#### 8.5 Conditions of Use:

The conditions of use in Section 5.0 apply with the following revisions:

- Revise Section 5.6 to say that when required by the code official, calculations showing compliance with the design requirements of Section 8.4.1.1 must be submitted to the code official for approval, except calculations are not required when the building design is based on the prescriptive method noted in Section 8.4.1.2. The calculations and details must be prepared by a registered design professional where required by the statutes of the jurisdiction in which the project is to be constructed.
- Revise Section 5.7 to say that in areas where the probability of termite infestation is defined as “very heavy” and when ICFs are used with wood construction, the foam plastic must be installed in accordance with Section 8.4.2.
- Revise Section 5.8 to say that concrete quality, mixing and placement must comply with 2006 IBC Section 1905 or 2006 IRC Section R611.6.1, as applicable.
- Revise Section 5.9 to say that special inspection must be in accordance with Section 8.4.4.
- Section 5.10 is not applicable.

#### 8.6 Evidence Submitted:

Data in accordance with the ICC-ES Acceptance Criteria for Stay-in-place, Foam Plastic Insulating Concrete Form (ICF) Systems for Solid Concrete Walls (AC353), dated October 2007 (editorially revised April 2008); and AC353 dated October 2010

#### 8.7 Identification:

See Section 7.0.



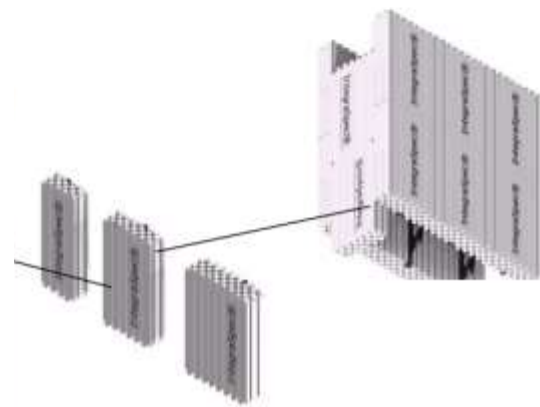
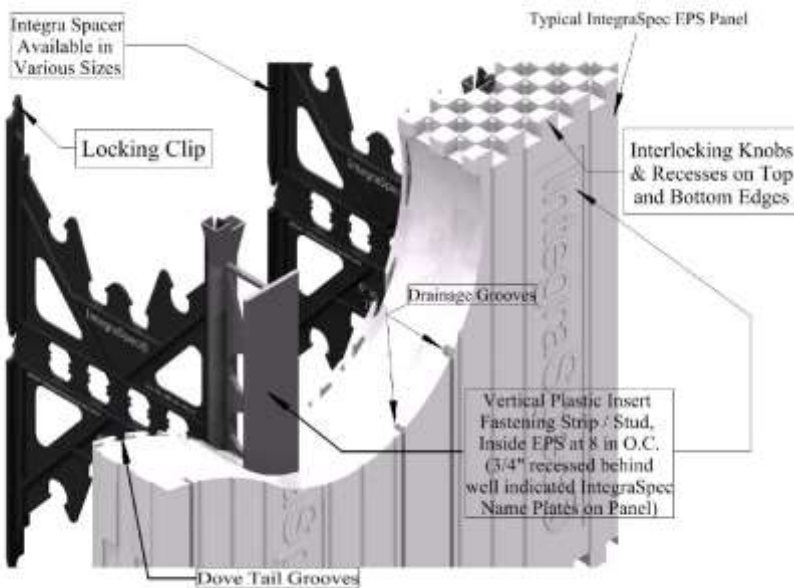
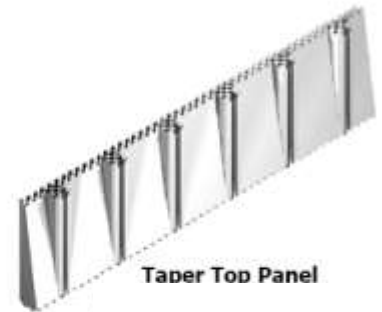
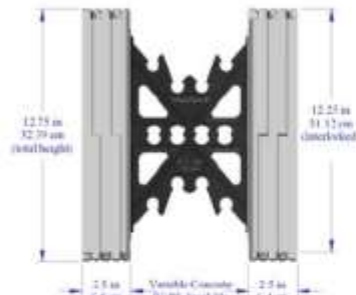
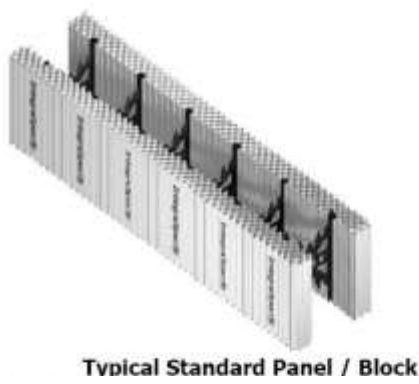
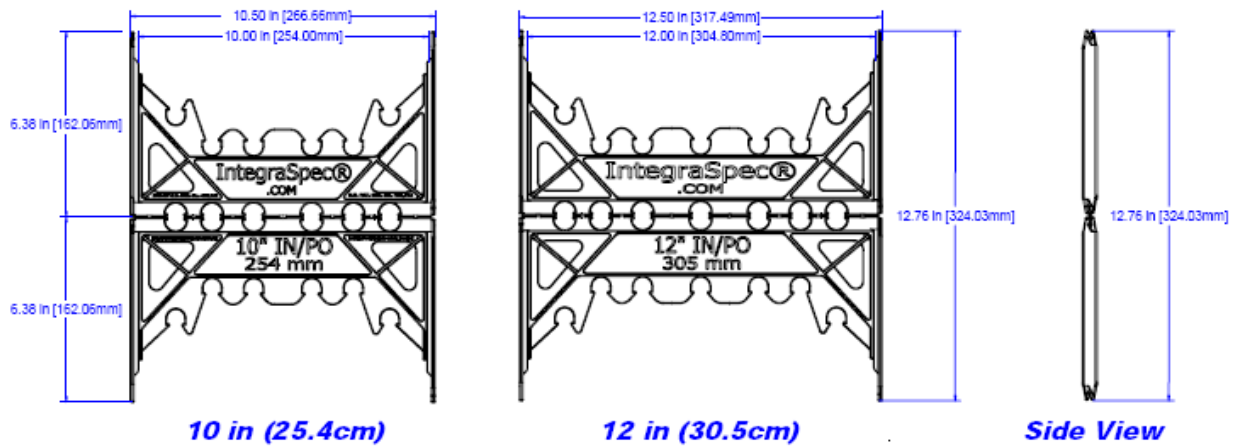
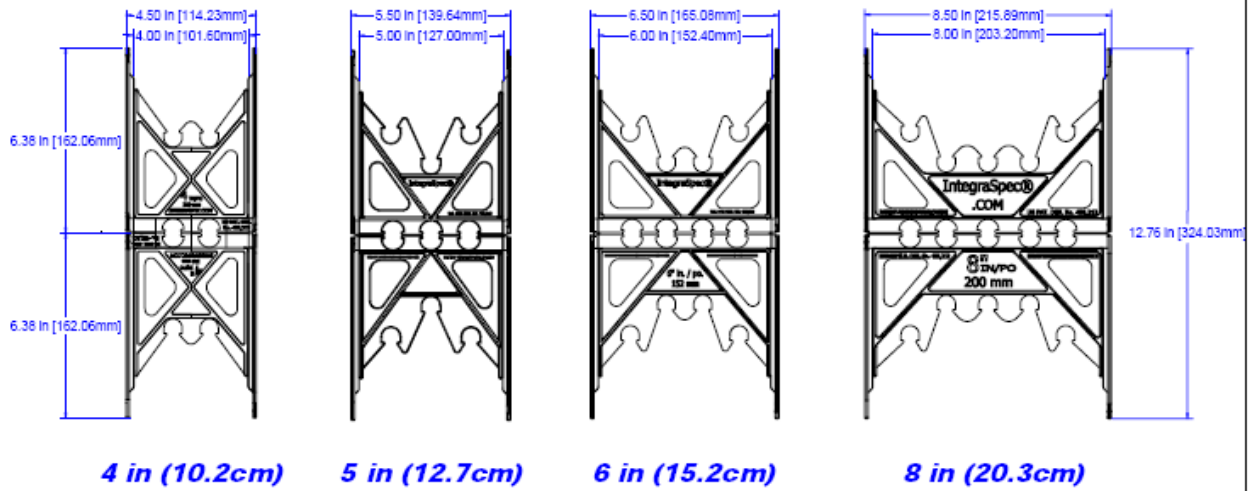

FIGURE 1

## IntegraSpec Spacers



## IntegraSpec Channel / Insert

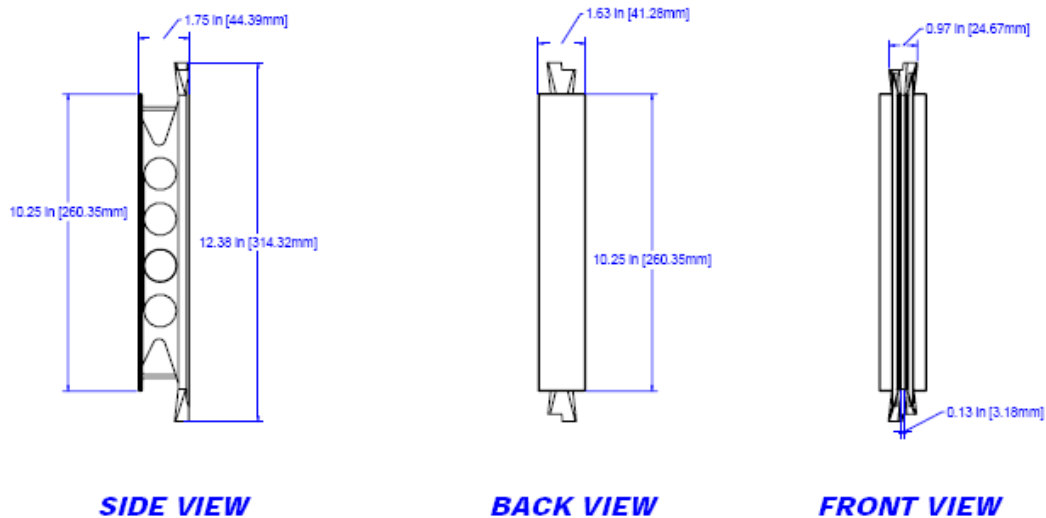

FIGURE 2

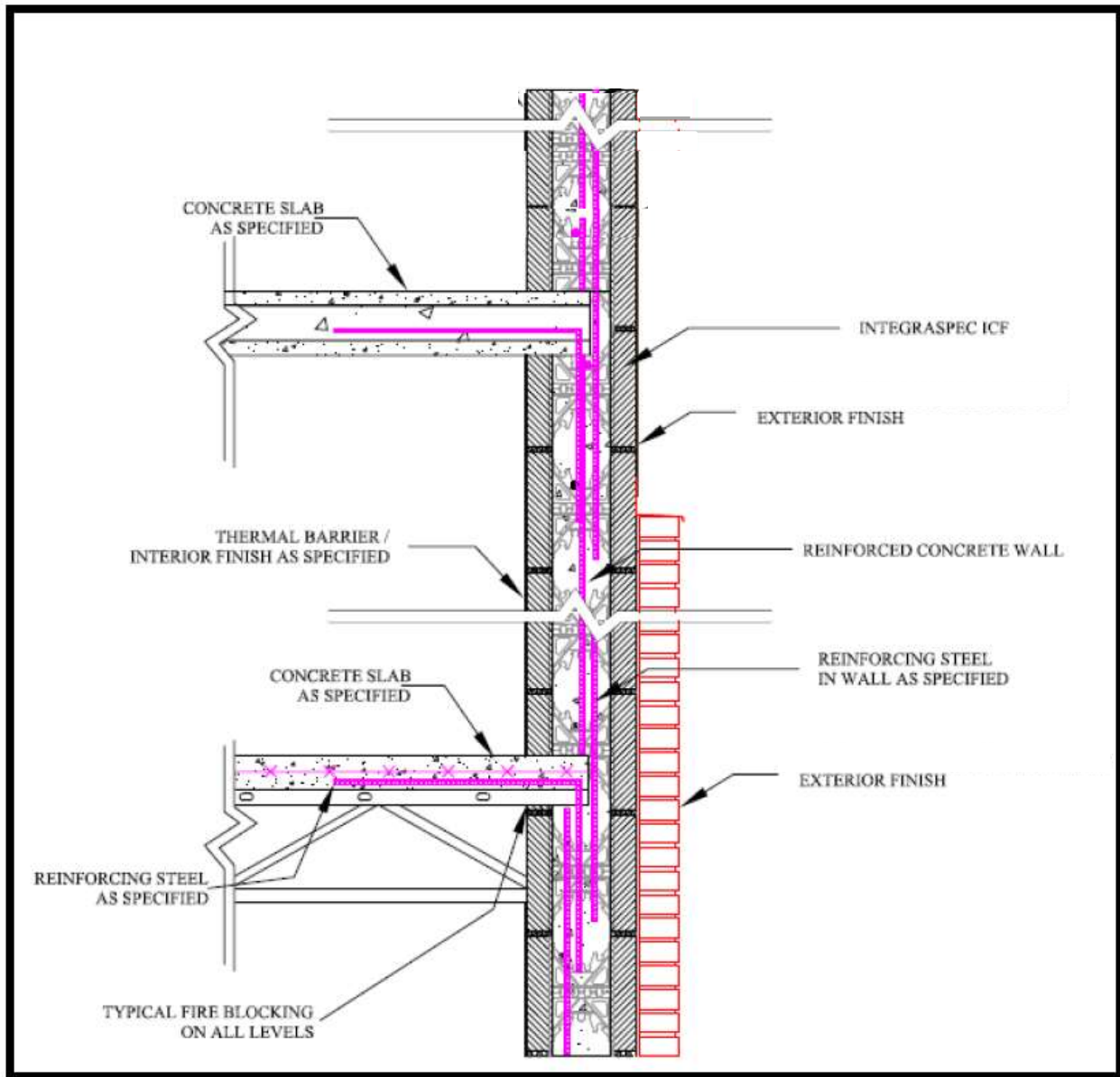

FIGURE 3—TYPICAL FLOOR-WALL FIRE-BLOCKING DETAIL FOR NONCOMBUSTIBLE CONSTRUCTION

**DIVISION: 03 00 00—CONCRETE**  
**Section: 03 11 19—Insulating Concrete Forming**

**REPORT HOLDER:**

**INTEGRASPEC CORPORATION**

**EVALUATION SUBJECT:**

**INTEGRASPEC INSULATING CONCRETE FORMS (ICF)**

## 1.0 REPORT PURPOSE AND SCOPE

**Purpose:**

The purpose of this evaluation report supplement is to indicate that Integraspec insulating concrete forms (ICFs), described in ICC-ES evaluation report ESR-1147, have also been evaluated for compliance with the codes noted below.

**Applicable code editions:**

- 2016 *California Building Code (CBC)*

For evaluation of applicable chapters adopted by the California Office of Statewide Health Planning and Development (OSHPD) AKA: California Department of Health Care Access and Information (HCAI) and the Division of State Architect (DSA), see section 2.1.1 and 2.1.2 below

- 2016 *California Residential Code (CRC)*

## 2.0 CONCLUSIONS

### 2.1 CBC:

The Integraspec insulating concrete forms (ICFs), described in Sections 2.0 through 7.0 of the evaluation report ESR-1147, comply with CBC Chapter 19, provided the design and installation are in accordance with the 2015 *International Building Code*® (IBC) provisions noted in the evaluation report and the additional requirements of CBC Chapters 16, 17, 18, 19 and 26 as applicable.

#### 2.1.1 OHSPD:

The Integraspec insulating concrete forms (ICFs), described in Sections 2.0 through 7.0 of the evaluation report ESR-1147, comply with CBC amended Chapter 19 [OSHPD 2] and CBC Chapter 19A [OSHPD 1 & 4], provided the design and installation are in accordance with the 2015 *International Building Code*® (IBC) provisions noted in the evaluation report, and the following conditions:

1. The design, installation and inspection are in accordance with the additional requirements of CBC Chapters 16, 17, 18 [OSHPD 2] and CBC Chapter 26 [OSHPD 2, as applicable].
2. In accordance with CBC Section 1903A.4 [OSHPD 1 & 4], flat wall insulating concrete form (ICF) systems are not permitted.

#### 2.1.2 DSA:

The Integraspec insulating concrete forms (ICFs), described in Sections 2.0 through 7.0 of the evaluation report ESR-1147, comply with CBC amended Chapter 19 [DSA-SS/CC] and CBC Chapter 19A [DSA-SS], provided the design and installation are in accordance with the 2015 *International Building Code*® (IBC) provisions noted in the evaluation report, and the following conditions:

1. The design, installation and inspection are in accordance with the additional requirements of CBC Chapter 16 [DSA-SS/CC], CBC Chapter 16A [DSA-SS], CBC Chapters 17A, 18A and 26 [DSA-SS and DSA-SS/CC], as applicable.

## **2.2 CRC:**

The Integraspec insulating concrete forms (ICFs), described in Sections 2.0 through 7.0 of the evaluation report ESR-1147, comply with CRC Chapter 6, provided the design and installation are in accordance with the 2015 *International Residential Code*<sup>®</sup> (IRC) provisions noted in the evaluation report and the additional requirements of CRC Chapters 3 and 4 as applicable.

This supplement expires concurrently with the evaluation report, reissued December 2023, and revised June 2024.